

ANGLE VALVE SHORT STEM

Reference: ACS 65 / ACR 66

Serie: C10110 (K.L.M.N.O.)

APPLICATIONS

Cryogenic Liquids, LNG, Liquefied Gases

Phase: Gas

Working Temperature

Maximum +160° C Minimum -212°

Maximum Working Pressure

50 Bar

Hydrostatic Test

75Bar

Standards Applied Cryogenic Bronze - ASTM UNS C93700, Valves and

components provided cleaned for use in oxygen, according to ASTM CGA G4.1



DIMENSIONAL TABLE (K. M.)

DN	MM	15	20	25	32	40	50	65	80
	Pol.	1/2"	3/4"	1"	1.1/4"	1.1/2"	2"	2.1/2"	3"
CODE		03	04	05	06	07	08	09	10
A		38	51	55	62	66	73	95	120
B		10	10	11	16	16	17	20	25
C		21,8	27,2	33,9	42,7	48,7	61,2	74,2	90,4
D (Open)		113,5	131,5	138	169	169	172	313,5	335
E (Closed)		158	171	179	204	204	220	405	421
F		183	205	212	236	236	259	459,5	486
Ø Handwheel		89	89	118	118	118	118	200	200

CONNECTION TABLE (L. N)

Description	Code	Standard
Thread NPT	01	AISI B1.20
Thread BSP	02	AISI BESEN10226-1
Copper Tube Connection	03	AISI B16.18
Butt Weld Schedule 10, 50 mm	06	AISI B36.19
Butt Weld Schedule 10, 100 mm	07	
Butt Weld Schedule 40, 50 mm	08	
Butt Weld Schedule 40, 100 mm	09	

SEAL TABLE (O)

Description	Code	Standard
PTFE	01	ASTM D4894
PCTFE	02	ASTM D1430
PTFE + 25% Fiber Glass	04	ASTM D4745
PTFE + 25% Carbon	05	

TABELA DE OPCIONAIS

Description	Code	Standard
Elongated Stem	001	MSS SP-134
Butt Weld	002	ASME B16.25
"C" Cote	003	N/A
Nickel Application	004	

Other connection are available

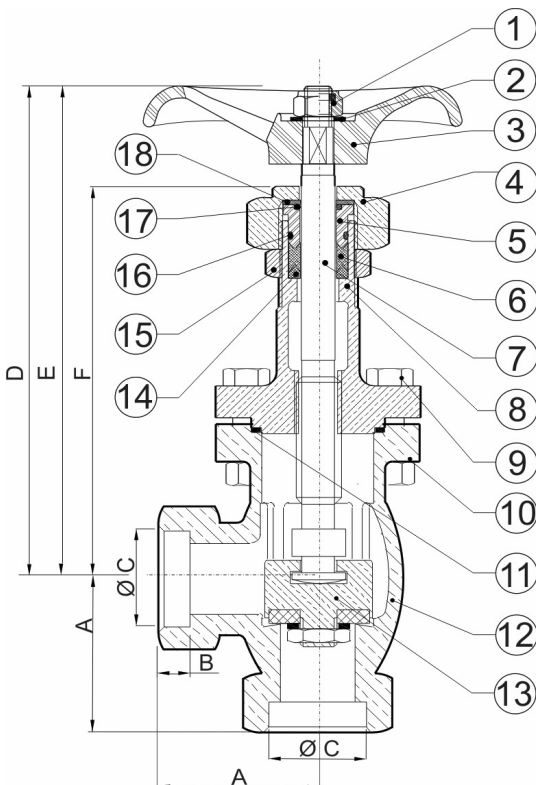

POS.	DENOMINAÇÃO	MATERIAL
1	HEX NUT	BRASS UNS 26800
2	WASHER	STAINLESS STEEL AISI
3	HANDWHEEL	ALUMÍNIO SAE 306
4	PREMI GASKET NUT	LATÃO UNS C36000
5	PREMI GASKET NUT	LATÃO UNS C36000
6	GASKET	PTFE ASTM D-1430-03
7	STEM	STAINLESS STEEL AISI
8	UPPER HEAD	ACC. DRAWING
9	HEX SCREW	STAINLESS STEEL AISI
10	HEX NUT	LATÃO ASTM B-283
11	GARNISH	PTFE ASTM D-1430-03
12	BODY	BRONZE UNS C93700
13	SEAL	ACC. DRAWING
14	PREMI WASHER	BRASS UNS C36000
15	LOCK NUT	BRASS UNS C36000
16	O'RING	FKM
17	O'RING	FKM
18	PRESSURE DISC	BRASS UNS C36000

Tables according to Grofé's standards. For special product, contact us.